

Name	FUNNEL WALL GU10 (for wall box)																																			
Reference	484737 484716 484776	TEXT. WHITE TEXT. BLACK TEXT. BLACK + GOLD																																		
	485737 485716 485776	TEXT. WHITE TEXT. BLACK TEXT. BLACK + GOLD																																		
Specifications	<table border="1"> <tr> <td>Safe distance to object</td> <td> - 0,1m - </td> </tr> <tr> <td>Lamp type</td> <td>Led par16</td> </tr> <tr> <td>CCT</td> <td></td> </tr> <tr> <td>Luminous flux</td> <td></td> </tr> <tr> <td>Power</td> <td>10W per lampholder</td> </tr> <tr> <td>Current</td> <td>230V 50-60Hz AC</td> </tr> <tr> <td>Forward voltage</td> <td></td> </tr> <tr> <td>Symbol</td> <td></td> </tr> <tr> <td>Gear</td> <td>Mains voltage</td> </tr> <tr> <td>IP / Class</td> <td>IP20</td> </tr> <tr> <td>Application</td> <td>Wall mounted</td> </tr> <tr> <td>Orientability</td> <td>None</td> </tr> <tr> <td>Dimmability</td> <td>See lamp</td> </tr> <tr> <td>Beamangle</td> <td></td> </tr> <tr> <td>CRI</td> <td></td> </tr> <tr> <td>SDCM</td> <td></td> </tr> <tr> <td>Weight</td> <td> 0,5 0,9</td> </tr> </table>		Safe distance to object	- 0,1m -	Lamp type	Led par16	CCT		Luminous flux		Power	10W per lampholder	Current	230V 50-60Hz AC	Forward voltage		Symbol		Gear	Mains voltage	IP / Class	IP20	Application	Wall mounted	Orientability	None	Dimmability	See lamp	Beamangle		CRI		SDCM		Weight	0,5 0,9
Safe distance to object	- 0,1m -																																			
Lamp type	Led par16																																			
CCT																																				
Luminous flux																																				
Power	10W per lampholder																																			
Current	230V 50-60Hz AC																																			
Forward voltage																																				
Symbol																																				
Gear	Mains voltage																																			
IP / Class	IP20																																			
Application	Wall mounted																																			
Orientability	None																																			
Dimmability	See lamp																																			
Beamangle																																				
CRI																																				
SDCM																																				
Weight	0,5 0,9																																			

GU
10

NL Installatie- en onderhoudsrichtlijnen m.b.t. de fabrieksgarantie.
1. De plaatsing, de aansluiting en het uittesten van dit toestel dient steeds te gebeuren door een erkend elektro-installeator.
2. Dit toestel moet geïnstalleerd, verbonden en getest worden volgens de nationaal geldende reglementen op elektrische installaties.
3. De technische bijsluiter dient te worden beschouwd als een onderdeel van de algemene verkoopsvoorwaarden van TAL nv.
4. De elektro-installeator is verantwoordelijk voor het gebruik van compatibele voorschakelapparatuur die voldoen aan de geldende IEC normen.
5. Reinig het toestel enkel met een zachte en lichtvochtige doek zonder reinigingsmiddel.
6. Schakel altijd eerst de elektriciteit uit alvorens het toestel te plaatsen en te installeren.

EN Installation and maintenance instructions regarding the manufacturer's warranty.
1. Installation, connection and testing of this product must always be performed by a certified electrician.
2. This product must be installed, connected and tested in accordance with the applicable national regulations for electrical installations.
3. The technical manual must be regarded as part of the general sales conditions of TAL nv.
4. The electrical installer is responsible for the use of compatible control gear that meets the applicable IEC standards.
5. Only clean the device with a soft and slightly moist cloth without detergent.
6. Always switch off the electricity supply before installing and connecting the product.

DE Installations- und Wartungsanweisungen bezüglich der Herstellergarantie.
1. Installation, Anschluß und Prüfung dieses Geräts soll nur von einem anerkannten Elektriker ausgeführt werden.
2. Dieses Gerät soll in Übereinstimmung mit den nationalen geltenden Vorschriften für Elektroinstallationen installiert, angeschlossen und geprüft werden.
3. Die technische Anleitung muß als Teil der allgemeinen Verkaufsbedingungen von TAL nv betrachtet werden.
4. Der Elektroinstallateur ist verantwortlich für die Verwendung von kompatiblen Betriebsgeräten, die den geltenden IEC-Normen entsprechen.
5. Reinigen Sie das Gerät nur mit einem weichen und leicht feuchten Tuch ohne Reinigungsmittel.
6. Schalten Sie den Strom immer aus, bevor Sie das Gerät installieren und anschließen.

FR Instructions d'installation et d'entretien concernant la garantie du fabricant.
1. L'installation, la connexion et les essais de cet appareil doivent toujours être effectués par un électricien reconnu.
2. Cet appareil doit être installé, raccordé et testé conformément aux réglementations nationales pour les installations électriques.
3. La notice technique doit être considérée comme faisant partie des conditions générales de vente de TAL SA.
4. L'installateur électrique est responsable de l'utilisation d'un équipement de contrôle compatible qui satisfait aux normes CEI applicables.
5. Nettoyez l'appareil uniquement avec un chiffon doux et légèrement humide sans détergent.
6. Éteignez toujours l'électricité avant d'installer et de connecter l'appareil.

Installation

A) Direct surface mounted on hollow wall:

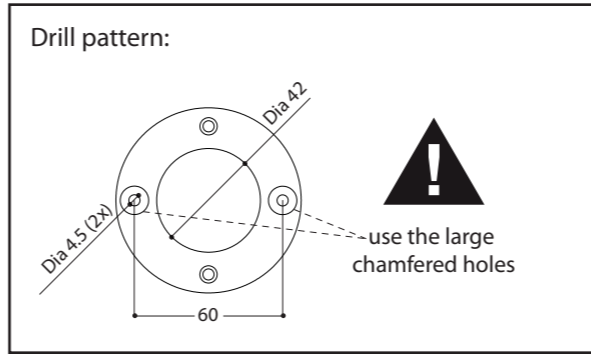
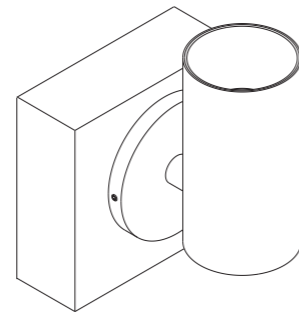

- 1 Drill a hole dia 42mm (depth 40mm) and make drillpattern as seen above.
- 2 Screw the base ring to the wall use the large chamfered holes !
- 3 Connect the wires via connectors and push connector through the base ring
- 4 Connect & mount the luminaire to the BASE RING

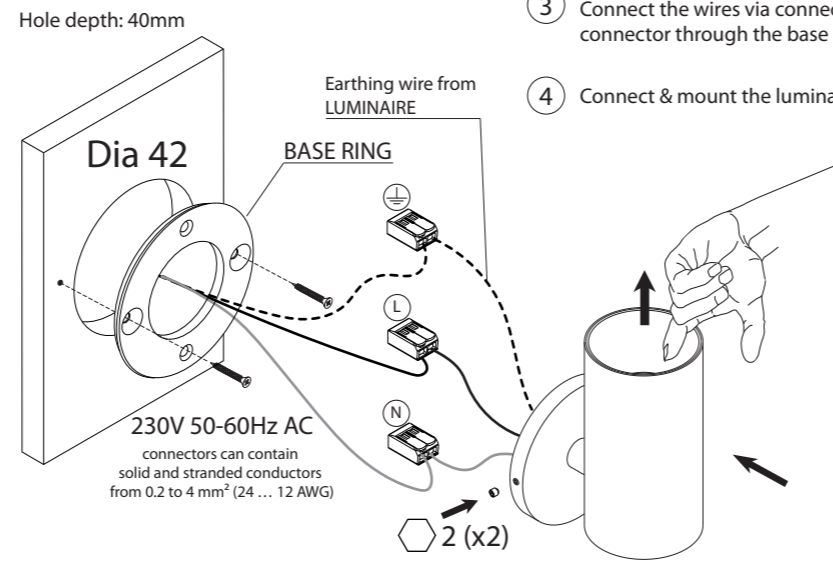

or double lamp version:

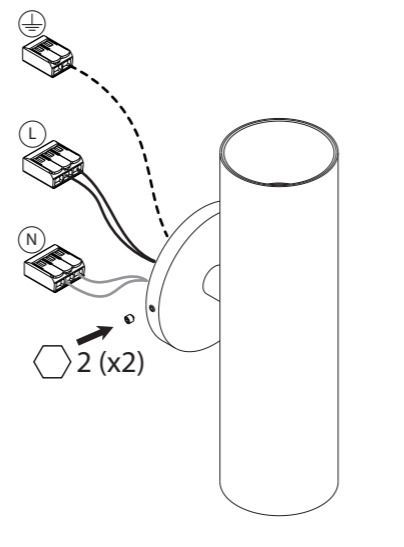

- 5 Pull out focusing by hand
Insert lamp Led par16 (twist and lock)
Turn on power supply

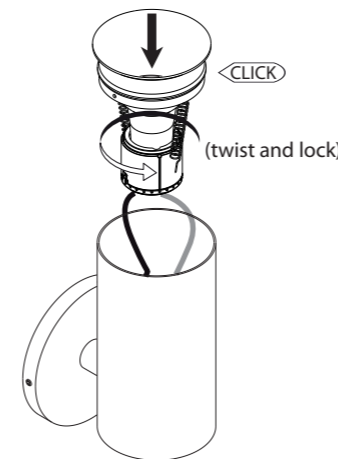

B) Recessed mounted in hollow wall on electrical accessory box:

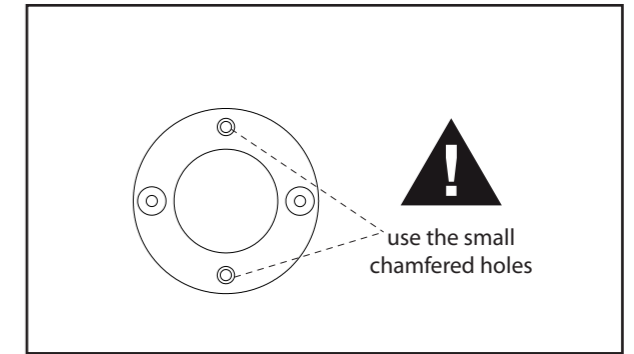
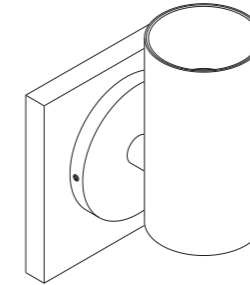

- 1 Drill a hole Ø68 (depth 40mm) and fit the electrical accessory box in wall.
- 2 Screw the base ring to the electrical accessory box using the small chamfered holes !
- 3 Connect the wires via connectors and push connector through the base ring
- 4 Connect & mount the luminaire to the BASE RING

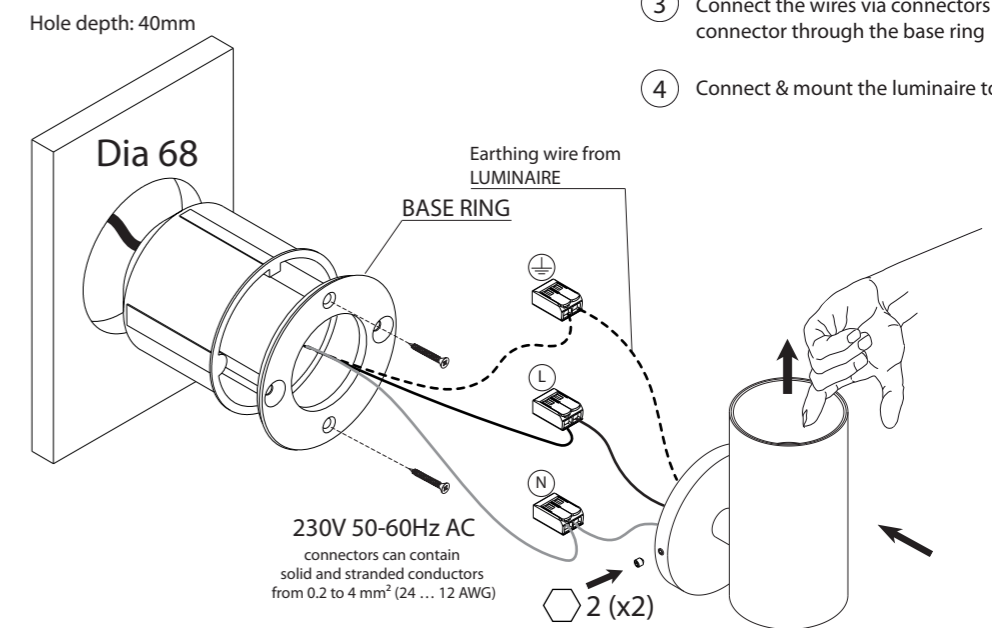

- 5 Pull out focusing by hand
Insert lamp Led par16 (twist and lock)
Turn on mains power supply

